

BITO

Die pfiffige Lösung

BITO-Regalwagen
Rack mobile BITO
Verrijdbare BITO-stelling
BITO Mobile shelving

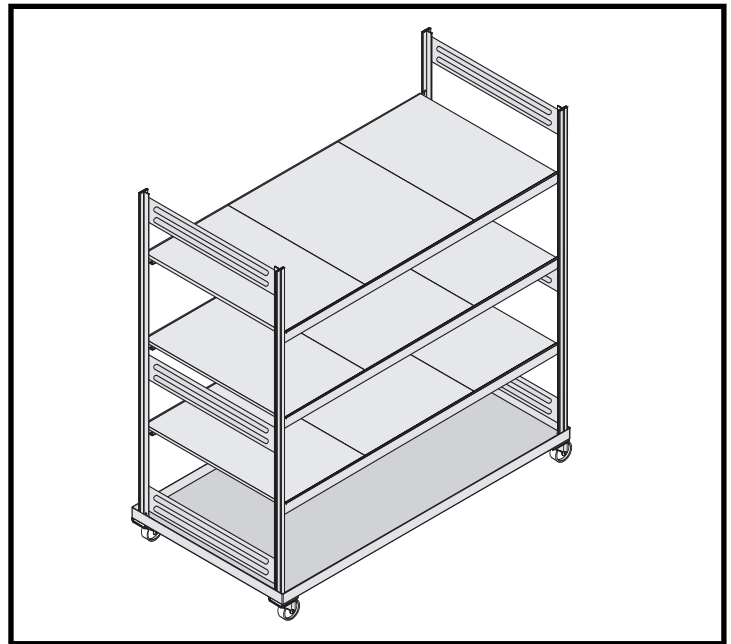

Aufbau- und Betriebsanleitung
Instructions de montage et d'utilisation
Richtlijnen en montagehandleiding
Instructions for assembly and use

Technische Änderungen vorbehalten. Modifications techniques réservées. Technische wijzigingen voorbehouden. Technical modifications reserved.



BITO-Regalwagen

Stand
06-2004

DIN EN ISO 9001



Inhalt / Sommaire / Inhoud / List of contents

Unbedingt beachten / Réglementations importantes /
Belangrijke richtlijnen / Important regulations

	Sicherheitsvorschriften Consignes de sécurité Veiligheidsvoorschriften Accident prevention regulations	2
	Sicherheitshinweis Renseignements de sécurité Veiligheidsopmerkingen Accident prevention advice	3
	Nivellierung Mise à niveau Nivellering Levelling	3

Übersicht / Sommaire / Inhoud / List of contents 5

Montage / Assembly

	Stützrahmen Echelle Stellingkader Frame	5
	Traverse Lisse Ligger Beam	5
	Unterzug Renfort Vloerondersteuning Support bar	6
	Spanplatte Panneau d'aggloméré Houtvezelvloer Chipboard shelf	6

Belastungen / Capacité de charge / Draagvermogen / Load capacity 7

Sicherheitsvorschriften / Consignes de sécurité
Veiligheidsvoorschriften / Accident prevention regulations

BGR 234 (ZH 1/428)

Richtlinien für Lagereinrichtungen und -geräte der Berufsgenossenschaften.

En tant que responsable de l'exploitation, veuillez respecter les réglementations de sécurité en vigueur.

Gebruikers dienen rekening te houden met de geldende nationale veiligheidsvoorschriften inzake magazijninrichtingen.

Users of the installation have to observe the relevant health and safety regulations.

Sicherheitshinweise / Renseignements de sécurité /
Veiligheidsopmerkingen / Accident prevention advice

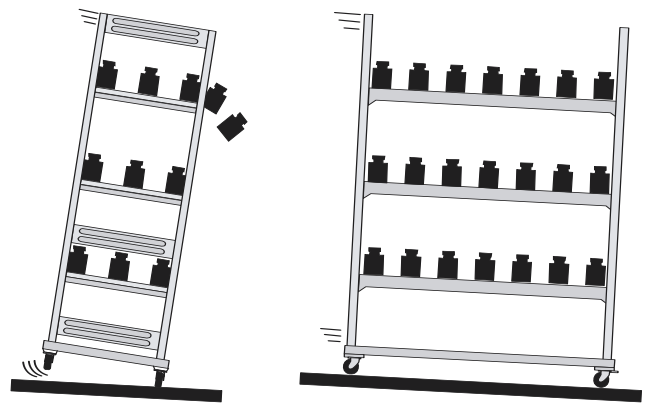

 **Auf schiefen Boden achten!**
Ne pas positionner sur sols en pente!
Niet op schuine vloeren plaatsen!
Do not place on sloping floors!

Nivellierung / Mise à niveau / Nivellering / Levelling

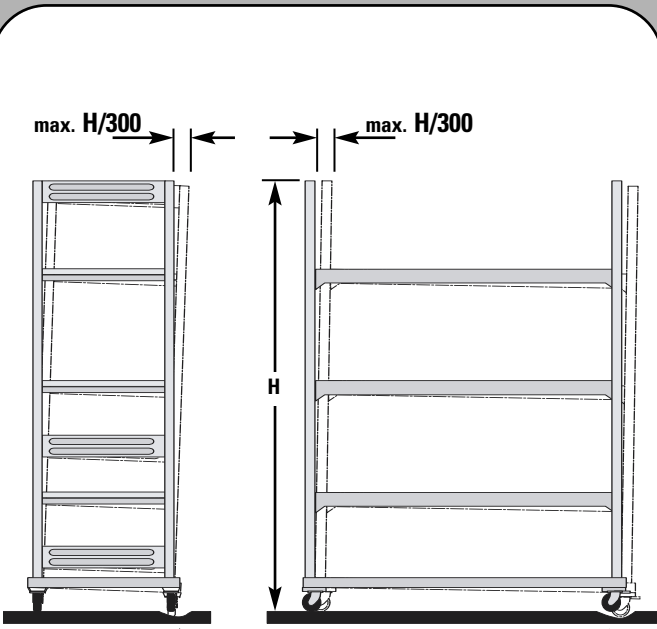

 **Auf Bodenunebenheiten achten**
Attention aux inégalités du sol
Let op vloeroneffenheden
Take possible floor unevenness into account



Übersicht
Sommaire
Inhoud
List of contents

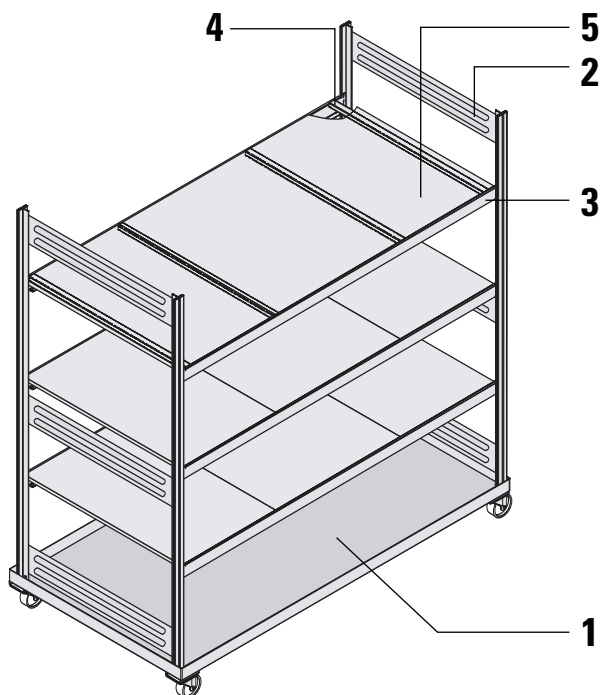

Seite
Page
Pagina
Page

1	Fahrgestell - komplett Base mobile - complète Verrijdbaar onderstel - compleet Mobile base - complete	5
2	Stützrahmen Echelle Stellingkader Frame	5
3	Traverse Lisse Ligger Beam	5
4	Unterzug Vloerondersteuning Renfort Support bar	6
5	Spanplatte Panneau d'aggloméré Houtvezelvloer Chipboard shelf	6



Traverse
Lisse
Ligger
Beam

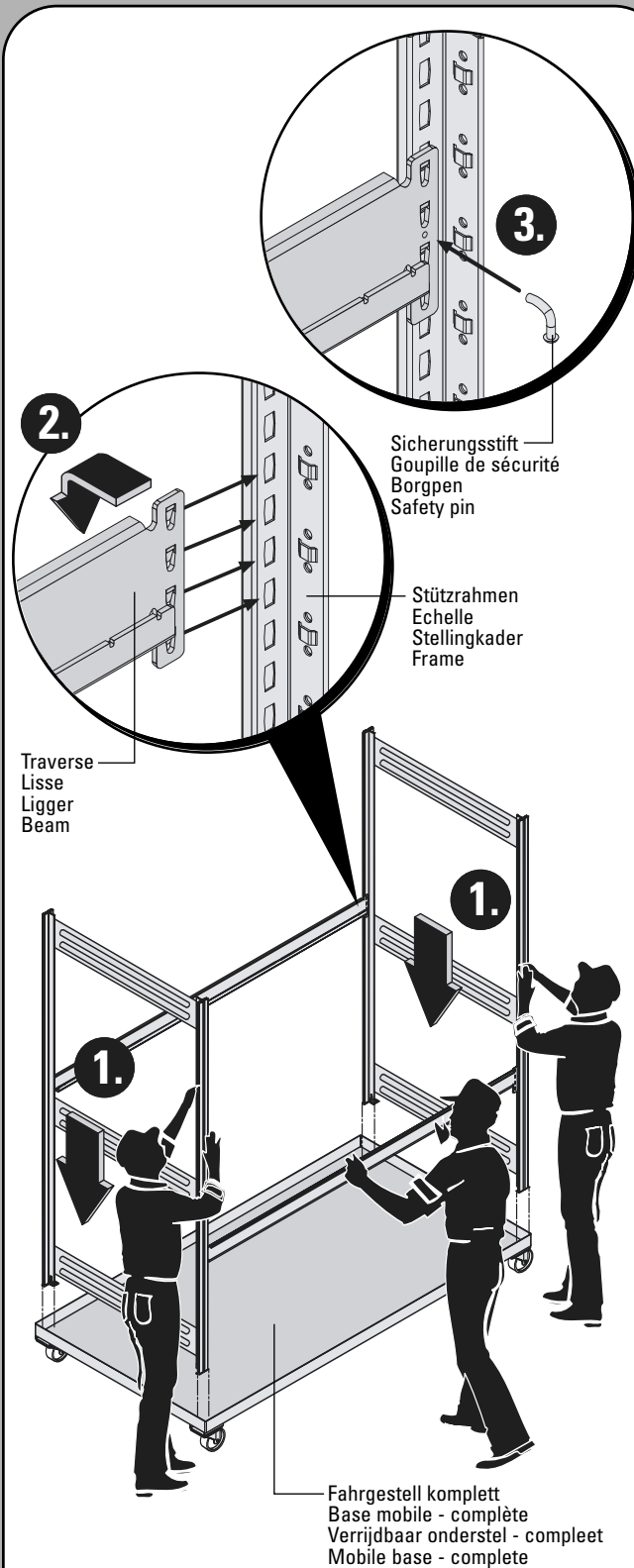
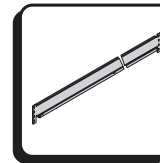

Nach dem Einhängen ist **jede Lasche** der Traverse sofort mit **einem Sicherungsstift** zu sichern.

Après avoir emboîté une lisse bloquer immédiatement **chaque connecteur** par **une goupille de sécurité**.

Ligger inhaken en onmiddellijk beveiligen tegen uitliften door **één borgpen** in **iedere inhaakverbinding** in te haken.

Hook beam into uprights and immediately secure **each connector** by inserting **one safety pin**.

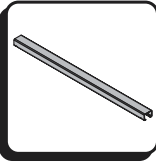

Unterzug
Renfort
Vloerondersteuning
Support bar

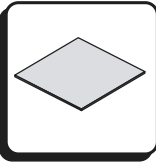
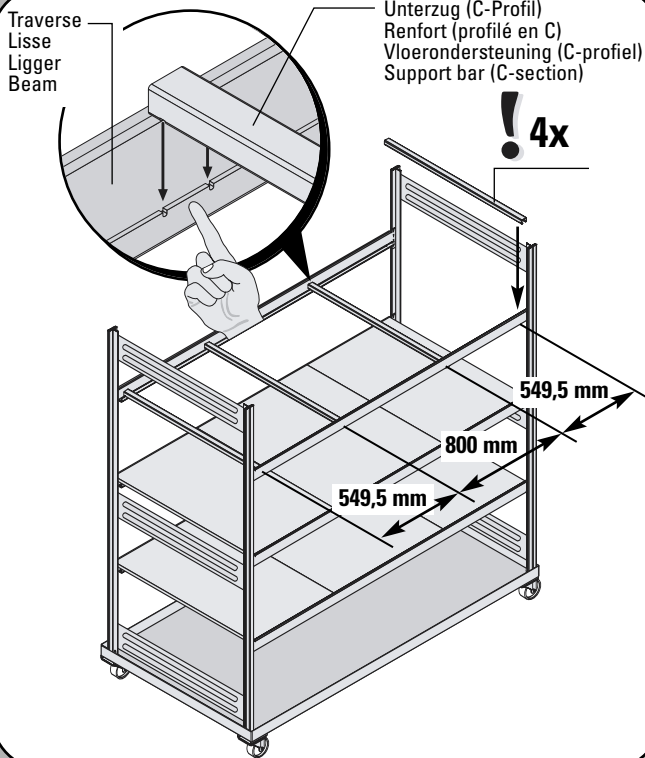

Spanplatte
Panneau d'aggloméré
Houtvezelvoer
Chipboard shelf

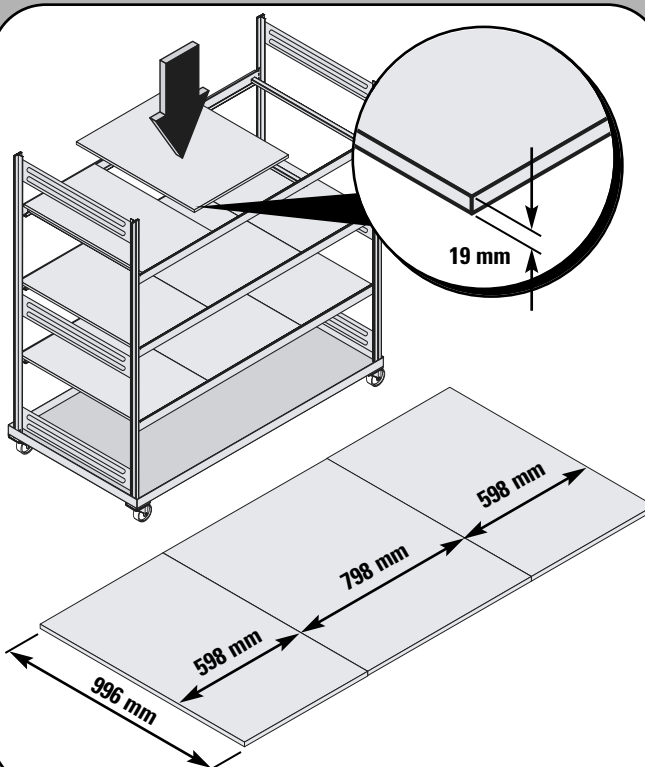

Belastung
Capacité de charge
Draagvermogen
Load capacity



! $\sum Q \leq Q_{max}$!

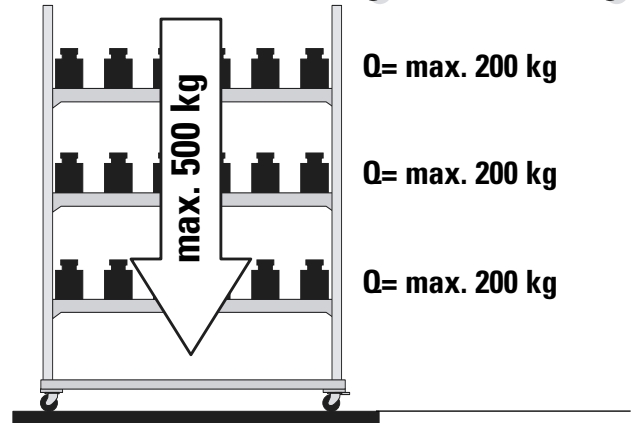

$Q_{max.} = 500 \text{ kg}$



! Gleichmäßig verteilte Last! !
! Charges uniformément réparties! !
! Gelijkmatig verdeelde belasting! !
! Evenly distributed loads! !

Q =
max. 200 kg

